

**AGA KHAN UNIVERSITY EXAMINATION BOARD**

**HIGHER SECONDARY SCHOOL CERTIFICATE**

**CLASS XII**

**ANNUAL EXAMINATIONS (THEORY) 2025**

**Physics Paper II**

**Time: 1 hour 30 minutes Marks: 35**

**INSTRUCTIONS**

**Please read the following instructions carefully.**

1. Check your name and school information. Sign if it is accurate.

**I agree that this is my name and school.  
Candidate's Signature**

**RUBRIC**

2. There are TEN questions. Answer ALL questions. Questions 9 & 10 each offer TWO choices. Attempt any ONE choice from each.
3. When answering the questions:  
  
Read each question carefully.  
Use a black pointer to write your answers. DO NOT write your answers in pencil.  
Use a black pencil for diagrams. DO NOT use coloured pencils.  
DO NOT use staples, paper clips, glue correcting fluid, or ink erasers.  
Complete your answer in the allocated space only. DO NOT write outside the answer box.
4. The marks for the questions are shown in brackets ( ).
5. You may use a scientific calculator if you wish.

Q.1. (Total 3 Marks)

Calculate the equivalent capacitance between the points A and B.

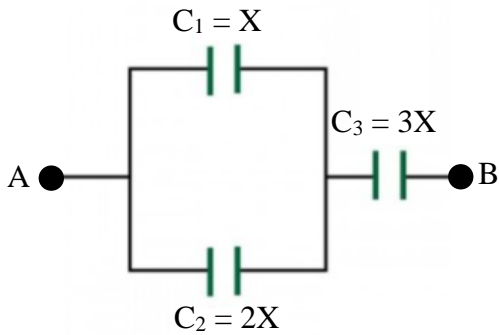

---

---

---

---

---

---

---

---

Q.2. (Total 3 Marks)

The given diagram shows a magnetic field normal to a metallic strip of width ( $d$ ) in which an electron ( $e$ ) moves with constant velocity ( $v$ ).

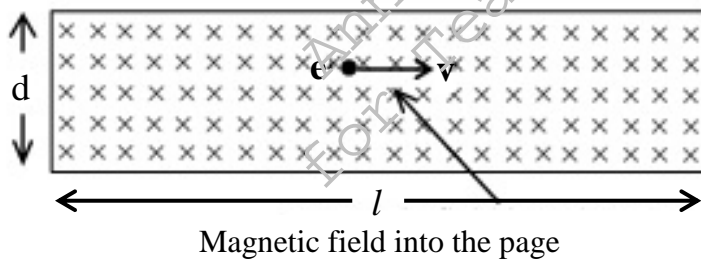

Deduce an equation for the magnetic force applied for the given case.

---

---

---

---

---

---

---

---

Q.3.

(Total 3 Marks)

Derive a relation for the energy stored in an inductor.

---

---

---

---

---

---

---

Q.4.

(Total 2 Marks)

State and explain TWO types of modulation.

---

---

---

---

Q.5.

(Total 2 Marks)

Differentiate between elastic and plastic deformations in solids by giving any TWO points.

S.No.	Elastic Deformations	Plastic Deformations
1		
2		

Q.6. (Total 3 Marks)

Describe TWO different types of biasing of a semiconductor diode.

---

---

---

---

---

---

---

---

Q.7. (Total 2 Marks)

In the process of inner shell transitions, explain the emission of the characteristics of X-rays.

---

---

---

---

---

Q.8. (Total 3 Marks)

Describe, in three steps, how a nuclear reactor generates electricity.

---

---

---

---

---

---

---

---

Q.9.

(Total 7 Marks)

**EITHER**

a.

- i. Make a circuit diagram of Wheatstone bridge. (4 Marks)
- ii. Derive the relationship between the resistances in a Wheatstone bridge circuit. (3 Marks)

**OR**

b. A cell of electromotive force (e.m.f.) 2.0 V provide power to an external circuit consisting of two resistors of  $12 \Omega$  each which are joined in parallel combination in a circuit and a voltmeter which reads a voltage of 1.6 V.

- i. Make a circuit diagram of the given situation. (4 Marks)
- ii. Calculate the internal resistance of the cell and the power dissipated by the internal resistance. (3 Marks)

---

---

---

---

---

---

---

---

---

---

---

---

---

---

---

---

---

---

---

---

---

---

---

---

---

---

Q.10.

(Total 7 Marks)

**EITHER**

a. Explain why the classical theory of light fails to account for the:

- i. concept of threshold frequency, (3 Marks)
- ii. direct proportionality between the intensity of incident light and the photoelectric current. (4 Marks)

**OR**

b.

- i. Define inertial and non-inertial frame of reference. (2 Marks)
- ii. Show that the Earth can be viewed both as an inertial and non-inertial frame of reference. (5 Marks)

Annual Examinations 2025  
AKU-EB  
For Teaching & Learning only

---

---

---

---

---

---

---

---

---

---

---

---

---

---

---

---

---

---

---

---

---

---

---

---

END OF PAPER

Please use this page for rough work

Annual Examinations 2025  
AKU-EB  
for Teaching & Learning only

Please use this page for rough work

AKU-EB  
Annual Examinations 2025  
for Teaching & Learning only